

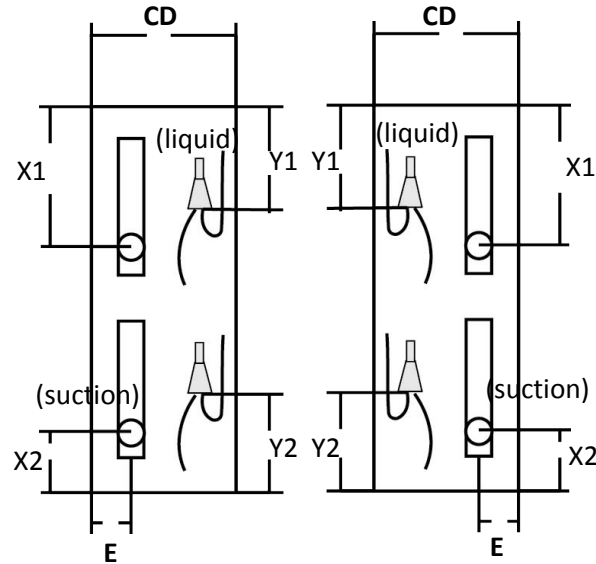

770-674-9100 | www.atrga.net

# DX Evaporator Coil - Face Split

**Coil Dimensions and Specifications:** (Please include detail photos of the coils and header sections - if available)

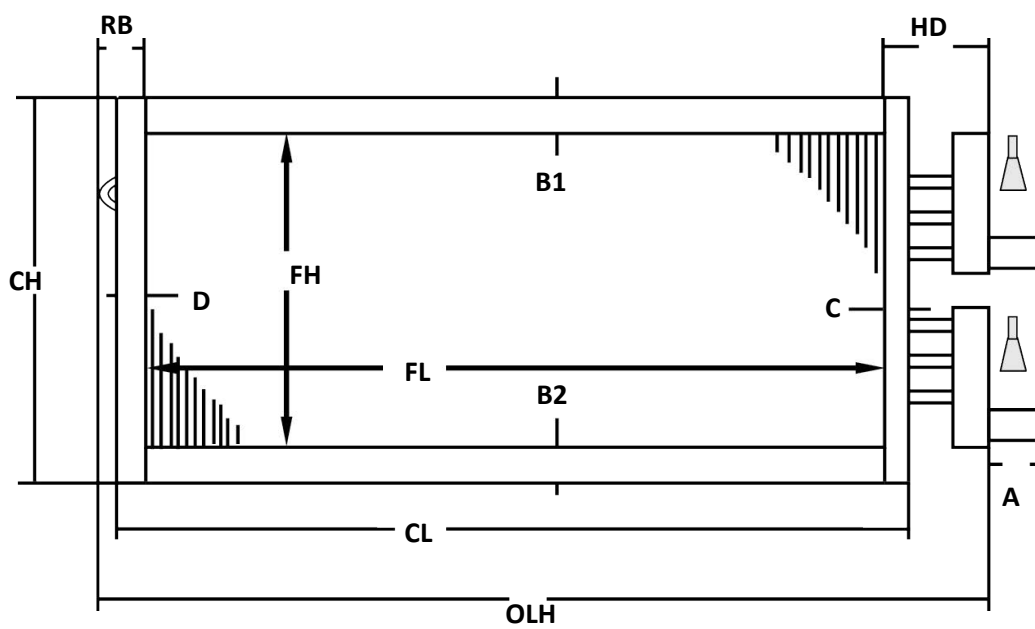

**\*\*Circle Header End Matching Your Coil\*\***

**Header Material:**

Copper

**# Tubes out from distributor:**

**Flange Type:**

- Standard
- Stacking
- Inverted Flange

**\*Casing Material: (check one)**

- Galv Steel 16 ga
- Stainless Steel 16 ga

*Rows	*FPI	*FH	*FL	CH	CL	CD	OLH	A	B1	B2	C	D	E	HD	RB	X1	X2	Y1	Y2

\* Asterisk items are minimum required for price

**Notes:**

<p><b>* COPPER</b></p> <table border="1"> <thead> <tr> <th>TUBE O.D.</th> <th>TUBE Thick</th> <th>FIN Thick</th> </tr> </thead> <tbody> <tr> <td><input type="checkbox"/> 3/8"</td> <td>.014</td> <td>.005</td> </tr> <tr> <td><input type="checkbox"/> 1/2"</td> <td>.016</td> <td>.006</td> </tr> <tr> <td><input type="checkbox"/> 5/8"</td> <td>.020</td> <td>.006</td> </tr> <tr> <td colspan="3">Other _____</td> </tr> </tbody> </table>	TUBE O.D.	TUBE Thick	FIN Thick	<input type="checkbox"/> 3/8"	.014	.005	<input type="checkbox"/> 1/2"	.016	.006	<input type="checkbox"/> 5/8"	.020	.006	Other _____			<p><b>*Fin Material:</b></p> <p>Aluminum (std)</p> <p>Copper</p>	<p><b>Refrigerant Type: (choose one)</b></p> <p>R-22</p> <p>R-410A</p> <p>Other: _____</p>	<p><b>Liquid O.D.</b></p> <p>_____</p> <p><b>Suction O.D.</b></p> <p>_____</p> <p><input type="checkbox"/> H.G.B.P</p>
	TUBE O.D.	TUBE Thick	FIN Thick															
<input type="checkbox"/> 3/8"	.014	.005																
<input type="checkbox"/> 1/2"	.016	.006																
<input type="checkbox"/> 5/8"	.020	.006																
Other _____																		
<p><b>Connection Material:</b></p> <p>Copper</p>	<p><b>Tonnage &amp; CFM:</b></p> <p>_____</p>																	

Name:	OEM Unit Model #
Company:	OEM Coil Model #
Phone:	Project:
Email:	Tag: