

**— AIR HANDLING EQUIPMENT —****SECTION #8**

INSTALLATION, OPERATION AND  
MAINTENANCE INFORMATION  
FOR:  
BELT DRIVE AIR HANDLERS  
HORIZONTAL & VERTICAL

**CALL US FIRST****USA COIL  
& AIR****1-800-USA-COIL****(800-872-2645)****(610) 296-9668**

U.S.A. Coil & Air, Inc.  
P.O. Box 578  
Devault, PA 19432

# HORIZONTAL UNITS - WHB & XHB

## INSTALLATION

### Optional equipment

1. Discharge grille / plenum.
2. Return air grille.
3. Two row hot water heating coil (reheat or preheat location).
4. Mixing boxes.
5. Motor and drive selections.
6. Steam coils (reheat or preheat)

### Step 1 - Ductwork

Use accepted industry practices and design guidelines of the ASHRAE FUNDAMENTALS HANDBOOK. Ductwork must comply with all building codes and the NATIONAL FIRE PROTECTION ASSOCIATION's pamphlet 90A and 90B.

Carefully inspect any previously installed ductwork to determine suitability.

**Note:** Ductwork should be of a size meeting requirements of the installation. Ductwork should transition gradually from a smaller size blower outlet to required duct run size to avoid excessive loss of air velocity.

### Step 2 - Check duct insulation and vapor proofing

Previously installed heating supply ductwork may already have adequate insulation against excessive heat loss. This insulation may be satisfactory for protection against heat gain from summer cooling. Depending upon application, it may be required to add more insulation.

Externally insulated ductwork must have adequate vapor seal for summer operation, particularly where duct is exposed to high humidity conditions such as in attic, vented crawl space, unconditioned basement or utility room.

### Step 3 - Place unit in ductwork.

1. When return air duct connection is smaller than coil inlet opening, construct the transition piece so that vertical and horizontal dimensions of transition do not increase more than one inch for every 7 inches of length.
2. Allow a minimum of 3 feet of straight ductwork preceding equipment inlet.
3. Install unit with  $\frac{1}{8}$  inch pitch toward condensate drain opening.

**Note:** Unit has a drain opening on each side. Ensure unused drain opening is sealed.

4. Suspend unit or support it from floor. The 2-5 ton models have  $\frac{3}{8}$ -16 weld nuts provided in each corner of the top for suspending the unit with threaded rod. (**Fig. 1.**) The 7.5-20 ton models have  $\frac{7}{8}$ " knockouts in each corner of top and base panels for suspension rods to pass through, located 3.5" in from corners on center line. It is recommended that angle iron or unistrut be used under

the unit for support (these support pieces should extend approximately 1" beyond each end of the length of the unit). (**Fig. 2.**)

### WARNING

BEFORE INSTALLING UNIT, DETERMINE WHETHER UNIT WEIGHT CAN BE SAFELY SUPPORTED. POSSIBLE INJURY AND DAMAGE MAY RESULT DUE TO JOIST / TRUSS OVERLOADING.

5. Be careful that suspension rods are located so they do not block access panels, nor interfere with electrical, mechanical or drain functions of unit.

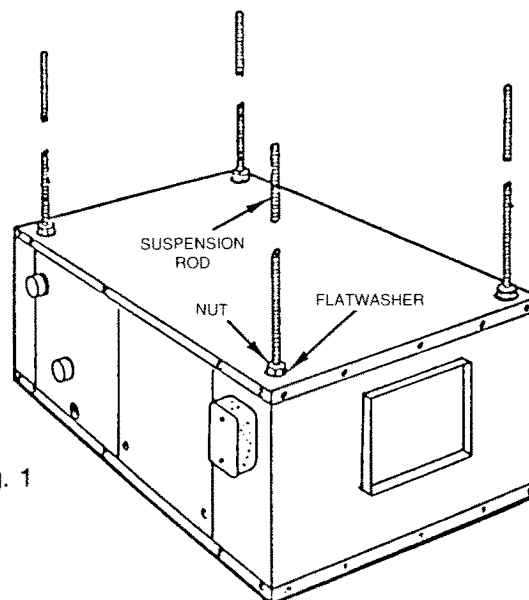

Fig. 1

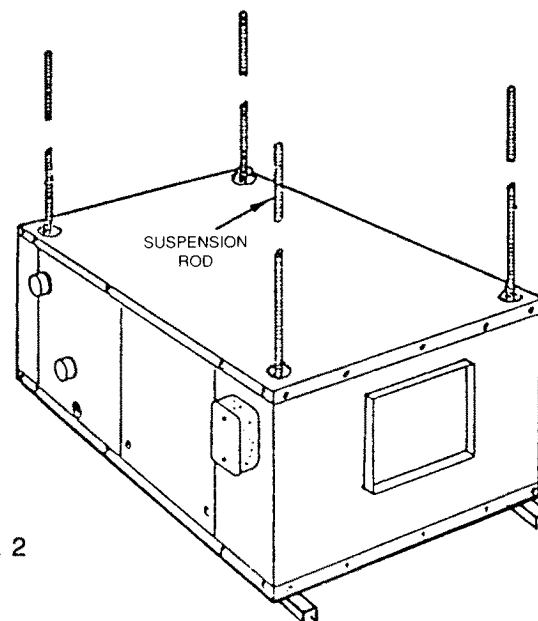

Fig. 2

#### Step 4 - Sound Attenuation

Flexible duct connections should be used between the unit and both the supply and return ducts. Unit vibration isolation will be required for both suspended and base mounted units.

#### Step 5 - Installation of Condensate Drain

Condensate drain must consist of a minimum of  $\frac{3}{4}$  in. copper tubing or  $\frac{3}{4}$  in. galvanized iron pipe or PVC-type plastic pipe. (Fig. 3.) The condensate drain trap must be properly designed to ensure the removal of condensate (Incorrect trapping can hold water in pan causing overflow.) Be sure drain pitches downward at a slope of one inch every 10 feet.

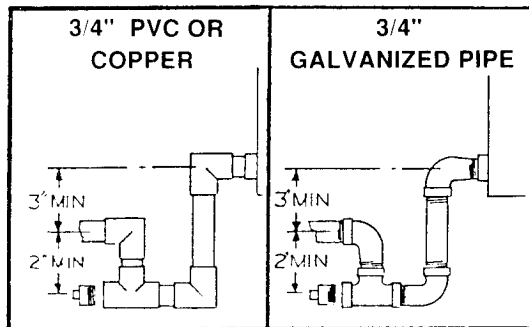

Fig. 3

#### CAUTION

If unit is located above an occupied space, or where damage can result from condensate overflow, install a watertight pan of corrosion-resistant metal beneath unit to catch any overflow due to restricted drain lines. A separate  $\frac{3}{4}$  in. condensate drain must be provided from this added pan. ( Fig. 4)

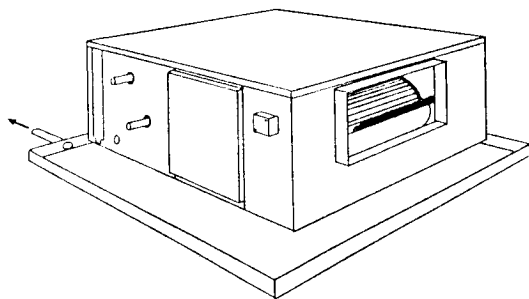

Fig. 4

Note: Consult local codes for additional precautions before installing condensate drain.

#### Step 6 - Direct expansion refrigerant piping

Always use the condensing unit manufacturer's recommended line sizes. The suction line must be insulated for satisfactory operation. Observe all con-

densing unit manufacturer's recommendation or requirements. Use refrigerant grade copper only. If unit is to be used when installed as the indoor coil of a heatpump, a by-pass check valve must be used.

Note: It is recommended that a freeze-stat (by other) be installed when a hot water coil is used and is mounted in the reheat position.

(Fig. 5) below shows the basic installation of a TXV and the location of the sensing bulb.

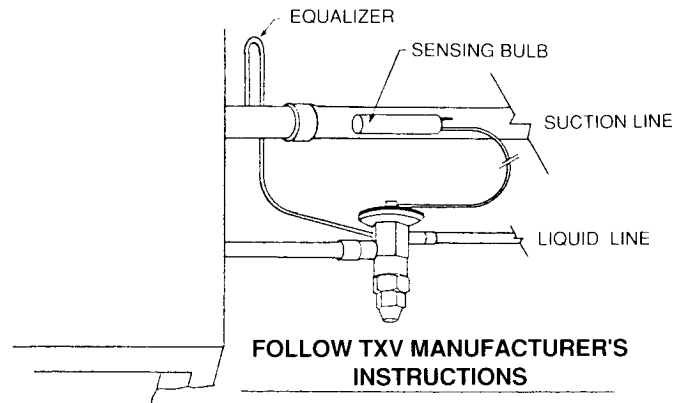
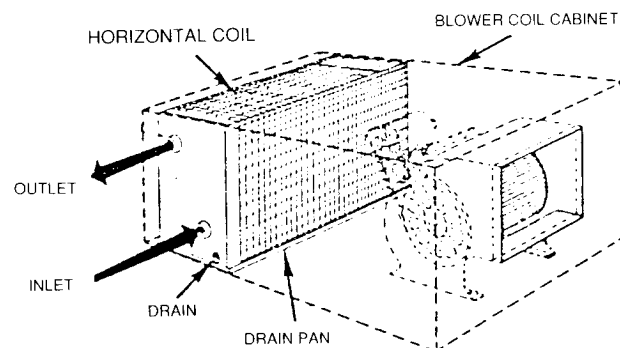

Fig. 5

#### Step 8 - Water Piping

All piping must be supported independent of coils. Swing joints or flexible fittings must be provided to absorb expansion and contraction strains. Rigid piping reduces the effectiveness of vibration isolators. The water supply should always be connected so that the entering water is on the leaving air side of the coil (Fig. 6.) Coils must be adequately vented in order to prevent air binding. Freeze-ups due to low entering air temps. are not covered under the USA Coil Warranty.



#### BLOWER COIL CONNECTIONS

(STANDARD RIGHT HAND UNIT)

Fig. 6

#### Step 9 - Motors and drives

Units will normally be shipped with motor and drive installed. However, when mounting a motor on the adjustable base in the field, extreme care should be taken to ensure proper alignment and belt tension.

### Step 10 - Electrical connections

A control box is mounted on each unit and the motor is to be wired to this box.

**Note:** Unit must be permanently grounded in accordance with NEC and local codes and ordinances. See typical wiring diagram. ( Fig. 7.)

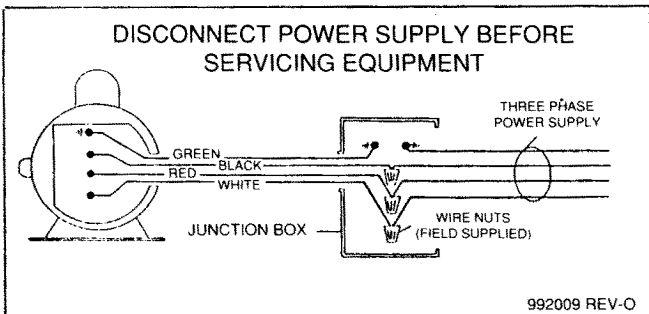
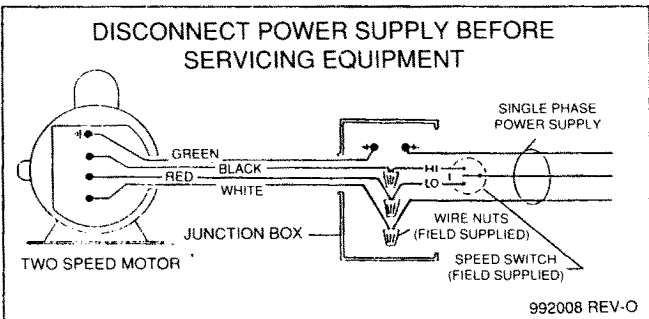
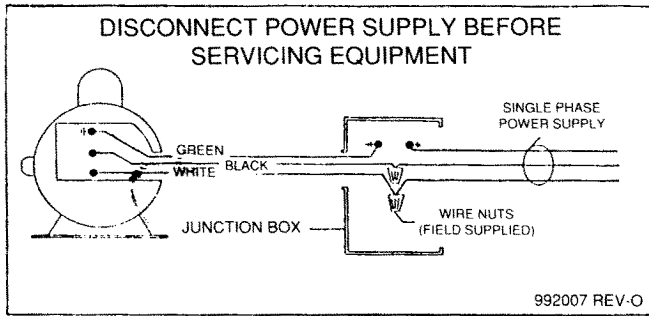

Fig. 7

### START-UP

Ensure all shipping bolts / screws are removed and all other bolts and screws are tight. Check the sheaves to see if they are in alignment and ensure the set screws are tight. Check for proper rotation of the blower pulley. Three phase motor rotation can be reversed by exchanging two of the three leads at the motor. Not all installations will be on starter. The rotation of single phase motors can be reversed by exchanging leads inside the motor junction box. Refer to motor nameplate. Ensure all filters are installed. Do this with all doors, panels, etc. in place. Check the amperage draw of the motor. This should not exceed the nameplate amps shown on the motor serial plate. Never assume the voltage and phase on the unit name plate is the same as the motor is wired.

### OPERATION AND MAINTENANCE

#### WARNING

Disconnect electrical power to all circuits before servicing unit. Failure to do so may result in personal injury from electrical shock or moving parts.

**RETURN AIR FILTERS** - Filter access is from either side of unit. Inspect on a regular basis (at least monthly) and clean or replace.

#### CAUTION

Never operate unit without a filter or with filter access door removed. Damage to blower motor may result.

### Step 8 - Water Piping - All Drain

Coil is easily cleaned when dry. To check or clean, remove unit access panel, filter access door and filters. Use accepted industry methods for cleaning. Remove all foreign matter from pan and condensate drain line. Check for rust and holes.

**BELT AND PULLEY** - Proper pulley alignment and belt tension must be maintained at all times. Speed is reduced by adjusting pulley faces so they are farther apart; speed is increased with faces closer together. Check pulley setscrews and bolts.

**MOTOR** - Use electric motor oil or SAE20 nondetergent oil. Tighten motor mount bracket and base bolts as required. **DO NOT OVER-OIL!!**

**BLOWER** - Check bearing for wear. Replace as required. Check wheel for accumulation of dirt and clean as required.

## HOT WATER COIL INSTALLATION INSTRUCTIONS (in reheat position)

1. Remove access panel from both sides of cabinet. See (Fig. 8.)
2. Remove knockouts from hot water coil stubouts. Coils stub out the cabinet for left-hand connections (facing airflow).
3. Remove 2 galvanized strips from hot water coil package. Install angle strip with notches resting in drain pan, and 1/2 in. flange pointing toward blower. Secure this angle strip to end plate of cooling coil by clips supplied in package. (Fig. 9.) Place clips at each end of strip as close as possible to flange.

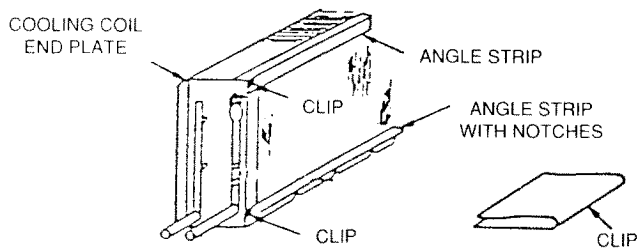

Fig. 8 - Installing Angle Strips

4. Install other angle strip at top of cooling coil, with 1/2 in. flange resting on top of cooling coil, pointing to rear. Place clip as high as possible on this strip. Secure it to end plate of cooling coil. Metal strips prevent air from bypassing heating coil and serve as support for coil.
5. After strips are secured, install coil inside through access door opposite side where connections stub out. Raise coil slightly above drain pan and line up stubouts with knockout holes in cabinet. When stubouts are extended through holes, hot water coil should rest on flange of bottom angle strip with hot water coil and cooling coil end plates lined up evenly.
6. Secure hot water coil to cooling coil by fastening 2 clips over cooling coil and hot water coil end plates, (Fig. 9).

*Note:* When used in reheat position with DX coil, install a freeze-stat in system to prevent freeze-up.

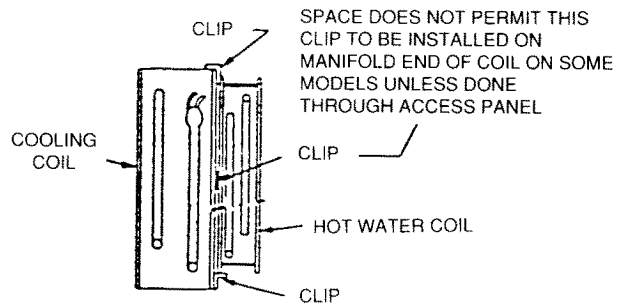

Fig. 9 - Securing Hot Water Coil

## HOT WATER COIL INSTALLATION INSTRUCTIONS (in preheat position)

Follow same procedures as before except cooling coil must be removed from cabinet.

## GRILLE PLENUM INSTALLATION

1. Mount grille plenum to front of cabinet using pre-punched holes in plenum.

*Note:* Some holes are 1/4 in. diameter and others are 1/2 in. diameter. Locations match screws in front of unit.

2. Remove screws from front of cabinet that line up with 1/4 in. holes in plenum. *Do not remove remaining screws.* The 1/2 in. holes in grille plenum clear the 1/2 in. screw heads in unit.
3. Line up grille plenum on front of unit. (Fig. 10).
4. Replace the screws removed previously, by reaching through grille opening. Tighten screws to secure the plenum.
5. Place grille in opening of plenum. Secure grille using screws provided.

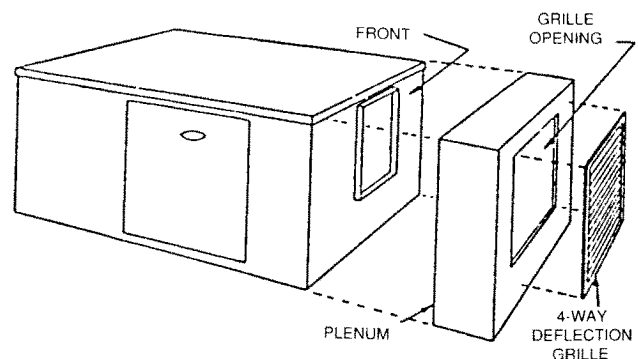

Fig. 10 - Grille Plenum Installation

6. Appropriate grille louvers may be adjusted manually, up-down, right-left, to provide 4-way air deflection.

## MIXING BOX INSTALLATION (Fig. 11)

### Before Installation

*Note:* See dimensions **Table 1** and **Fig. 11**. Inspect desired installation location. Determine if space provides sufficient work and safety clearances. If determined that ample space is available in work area, make all sheet metal connections and attachments prior to moving completed assembly to duct connection site.

1. One side of mixing box has 2 plastic plugs. These may be removed and moved to opposite end to plug unused  $\frac{7}{8}$  in. holes in end of cabinet where  $\frac{5}{16}$  in. rods do not extend out of cabinet.
2. Choose side of cabinet most accessible for servicing to mount damper motor. Remove bolt for each damper shaft on that end and extend shaft until second bolt hole in shaft lines up with hole in damper blade. Replace bolt. Connect 2 shafts with the 2 crankarms, and the  $\frac{5}{16}$  in. linkage rod furnished with mixing box.

3. Mount damper motor on the selected side of mixing box cabinet by drilling necessary holes and securing with either screws or bolts and nuts.

### Installation

1. Attach mixing box to unit return-air duct flange. Vertical duct flange connections at rear of unit are prepunched to match prepunched holes in mixing boxes. Mixing boxes may be mounted for top-rear or bottom-rear connections.
2. After vertical flange has been bolted, drill holes in horizontal duct flanges. Secure with screws or bolts and nuts.
3. Use field-supplied hardware to connect motor shaft to one of the damper shafts.
4. Connect duct to the 1" duct flange provided on mixing box for return and fresh air makeups as needed.

*Note:* Steps 1, 2, 3 above may follow steps 1, 2 under Before Installation if preferred.

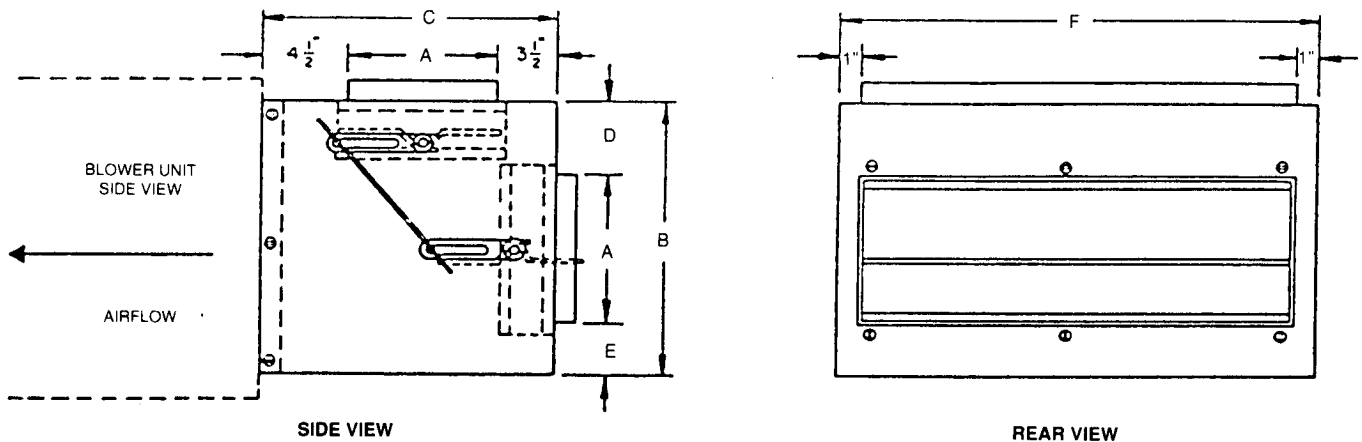

Fig. 11 - Mixing Box Dimensions

**DIMENSIONS TABLE 1**

MODEL	A	B	C	D	E	F	DAMPER	SHIPPING WT.	CFM.	S.P.
24-MB	8	16	16	6	2	18	2- 16 X 8	44	800	.07"
36-MB	8	16	16	6	2	27 $\frac{1}{2}$	2- 26 X 8	49	1200	.08"
48-MB	8	20	16	8	4	29	2- 28 X 8	53	1600	.10"
60-MB	8	20	16	8	4	36	2- 34 X 8	63	2000	.07"
90-MB	10	25	18	8	7	45	2- 44 X 10	101	3000	.06"
120-MB	12	32	20	10	10	48	2- 46 X 12	120	4000	.03"
180-MB	14	40 $\frac{1}{4}$	22	12	14 $\frac{1}{4}$	58	2- 56 X 14	197	6000	.05"
240-MB	14	45	22	15	16	66	2- 56 X 14	205	8000	.04"

# SMALL & MEDIUM VERTICAL UNITS - SWVB & SXVB

## INSTALLATION

### Optional equipment

1. Discharge plenum.
2. Return air plenum.
3. Two row hot water heating coil (reheat or preheat location).
4. Electric heat.
5. Motor and drive selections.
6. Steam coils (reheat or preheat)
7. Heat pump kit

### Step 1 - Ductwork

Use accepted industry practices and design guidelines of the ASHRAE FUNDAMENTALS HANDBOOK. Ductwork must comply with all building codes and the NATIONAL FIRE PROTECTION ASSOCIATION's pamphlet 90A and 90B.

Carefully inspect any previously installed ductwork to determine suitability.

*Note:* Ductwork should be of a size meeting requirements of the installation. Ductwork should transition gradually from a smaller size blower outlet to required duct run size to avoid excessive loss of air velocity.

### Step 2 - Check duct insulation and vapor proofing

Previously installed heating supply ductwork may already have adequate insulation against excessive heat loss. This insulation may be satisfactory for protection against heat gain from summer cooling. Depending upon application, it may be required to add more insulation.

Externally insulated ductwork must have adequate vapor seal for summer operation, particularly where duct is exposed to high humidity conditions such as in attic, vented crawl space, unconditioned basement or utility room.

### Step 3 - Ductwork.

1. When return air duct connection is smaller than coil inlet opening, construct the transition piece so that vertical and horizontal dimensions of transition do not increase more than one inch for every 7 inches of length.
2. Allow a minimum of 3 feet of straight ductwork preceding equipment inlet.
3. Install unit with  $\frac{1}{8}$  inch pitch toward condensate drain opening.

### Step 4 - Sound Attenuation

Flexible duct connections should be used between the unit and both the supply and return ducts.

### Step 5 - Installation of Condensate Drain

Condensate drain must consist of a minimum of  $\frac{3}{4}$  in. copper tubing or  $\frac{3}{4}$  in. galvanized iron pipe or PVC-type plastic pipe. (**Fig. 1.**) The condensate drain trap must be properly designed to ensure the removal of condensate (Incorrect trapping can hold water in pan causing overflow.) Be sure drain pitches downward at a slope of one inch every 10 feet.

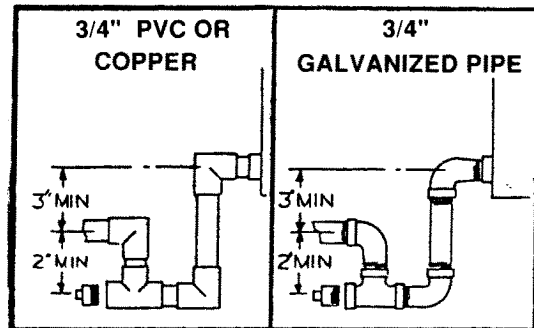

Fig. 1

*Note:* Consult local codes for additional precautions before installing condensate drain.

### Step 6 - Direct expansion refrigerant piping

Always use the condensing unit manufacturer's recommended line sizes. The suction line must be insulated for satisfactory operation. Observe all condensing unit manufacturer's recommendation or requirements. Use refrigerant grade copper only. If unit is to be used when installed as the indoor coil of a heatpump, a by-pass check valve must be used. (See page 7.)

*Note:* It is recommended that a freeze-stat (by other) be installed when a hot water coil is used and is mounted in the reheat position.

(**Fig. 2**) below shows the basic installation of a TXV and the location of the sensing bulb.

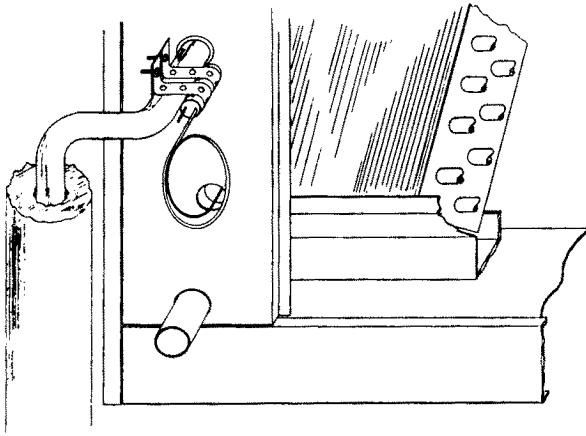

Fig. 2

**Step 7 - Water Piping**

All piping must be supported independent of coils. Swing joints or flexible fittings must be provided to absorb expansion and contraction strains. Rigid piping reduces the effectiveness of vibration isolators. The water supply should always be connected so that the entering water is on the leaving air side of the coil. Coils must be adequately vented in order to prevent air binding. Freeze-ups due to low air temps. are not covered under the USA Coil Warranty.

**Step 8 - Motors and drives**

Units will normally be shipped with motor and drive installed. However, when mounting a motor on the adjustable base in the field, extreme care should be taken to ensure proper alignment and belt tension.

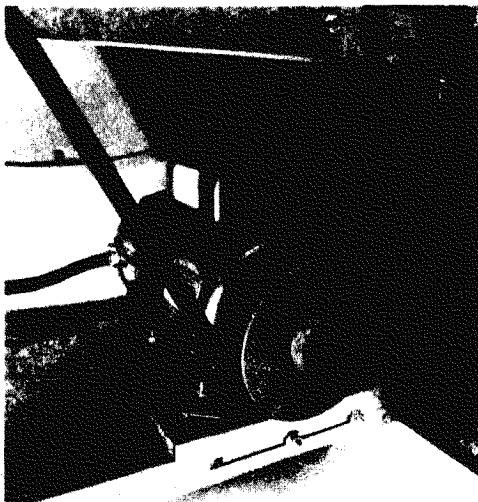

**Step 9 - Electrical connections**

A control box is mounted on each unit and the motor is to be wired to this box.

**Note:** Unit must be permanently grounded in accordance with NEC and local codes and ordinances. See typical wiring diagram. ( Fig. 3.)

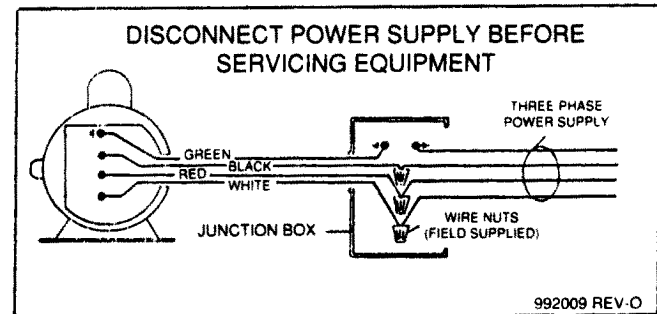
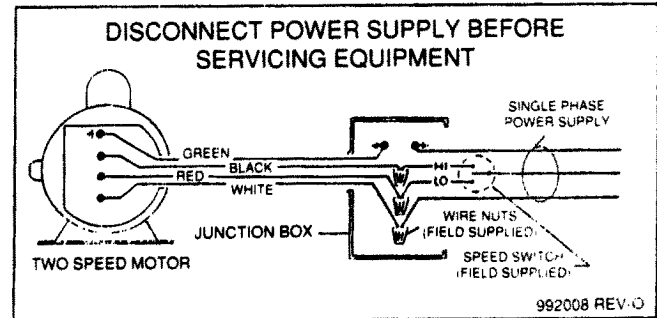
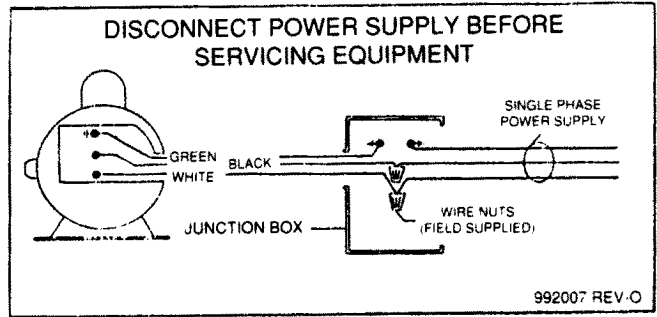

Fig. 3



## INSTALLATION OF COILS

The chilled water, direct expansion and hot water coils are shipped separate from unit cabinet. In order to install, remove both the manifold and coil access panel. Slide heating coil (Fig. 4) in appropriate tracks. Slide cooling coil (Fig 5) in appropriate track. Replace the manifold panel and then the coil access panel.

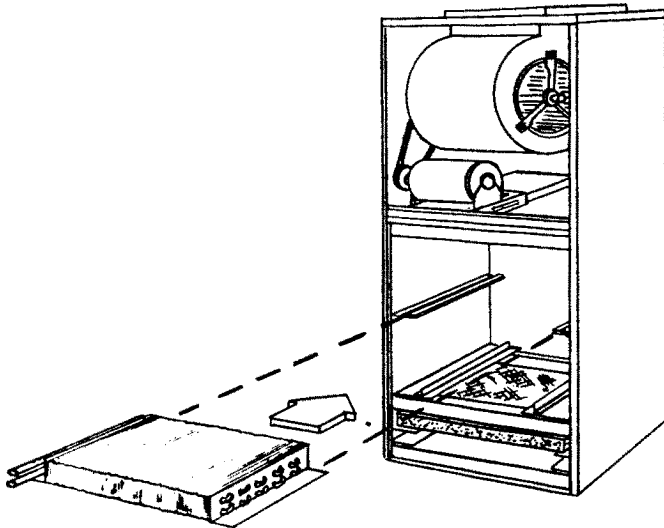

Fig. 4

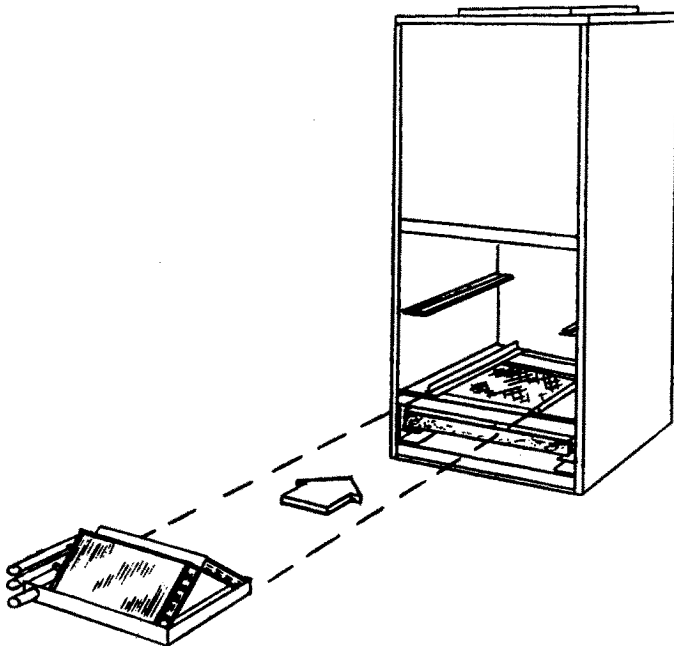

Fig. 5

## INSTALLATION OF DISCHARGE RETURN AIR PLENUM

One plenum serves a dual purpose. (Fig. 6) Once the location is determined, either on top of unit or underneath, remove the side panel. Square up the cabinets and secure with sheet metal screws (not provided). The size and location of the openings are to be determined by contractor and then field cut. If the side panel is not to be used then it should be placed back on the plenum.

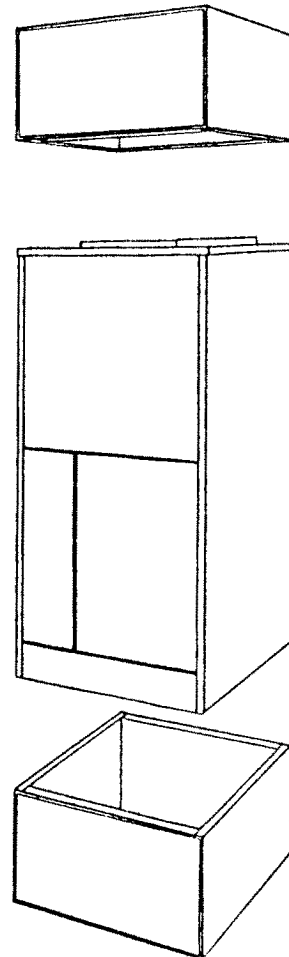
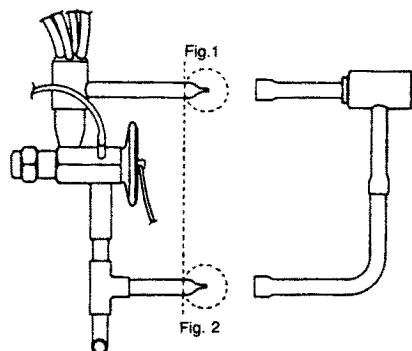

Fig. 6

## OPTIONAL HEAT PUMP BYPASS ASSEMBLY FOR SXVB SERIES



Expansion Valve  
Distributor Assembly  
as it appears on  
the BVX Units

Check Valve Bypass  
Assembly

### INSTALLATION PROCEDURE

1. Cut off the ends of the stub-out tubes near the location of the dotted line. (See Figure 1 & 2)
2. Slip the swedged ends of the bypass kit over the open tube ends where the ends were cut off.
3. Make sure the bypass assembly is in the same position as shown above.
4. Braze the two joints and then check to be sure there are no leaks in the welded joints.

### START-UP

Ensure all shipping bolts / screws are removed and all other bolts and screws are tight. Never assume the voltage and phase on the unit name plate is the same as the motor is wired. Check the sheaves to see if they are in alignment and ensure the set screws are tight. Check for proper rotation of the blower pulley. Three phase motor rotation can be reversed by exchanging two of the three leads at the unit j box. Not all installations will be on starter. The rotation of single phase motors can be reversed by exchanging leads inside the motor junction box. Refer to motor nameplate. Ensure all filters are installed. Do this with all doors, panels, etc. in place. Check the amperage draw of the motor. This should not exceed the nameplate amps shown on the motor serial plate.

### OPERATION AND MAINTENANCE

#### WARNING

Disconnect electrical power to all circuits before servicing unit. Failure to do so may result in personal injury from electrical shock or moving parts.

**RETURN AIR FILTERS** - Filter access is from either side of unit. Inspect on a regular basis (at least monthly) and clean or replace.

#### CAUTION

Never operate unit without a filter or with filter access door removed. Damage to blower motor may result.

#### - Water Piping - All Drain

Coil is easily cleaned when dry. To check or clean, remove unit access panel, filter access door and filters. Use accepted industry methods for cleaning. Remove all foreign matter from pan and condensate drain line. Check for rust and holes.

**BELT AND PULLEY** - Proper pulley alignment and belt tension must be maintained at all times. Speed is reduced by adjusting pulley faces so they are further apart; speed is increased with faces closer together. Check pulley setscrews and bolts.

**MOTOR** - Use electric motor oil or SAE20 nondetergent oil. Tighten motor mount bracket and base bolts as required. **DO NOT OVER-OIL!!**

**BLOWER** - Check bearing for wear. Replace as required. Check wheel for accumulation of dirt and clean as required.

# LARGE VERTICAL UNITS - LWVB & LXVB

## OPTIONAL EQUIPMENT

1. Discharge grille / plenum.
2. Return air grille.
3. Two row hot water heating coil (reheat or preheat location).
4. Mixing boxes.
5. Motor and drive selections.
6. Steam coils (reheat or preheat)
7. Electric Heat (Field installed)

## INSTALLATION

### Step 1 - Ductwork

Use accepted industry practices and design guidelines of the ASHRAE FUNDAMENTALS HANDBOOK. Ductwork must comply with all building codes and the NATIONAL FIRE PROTECTION ASSOCIATION'S pamphlet 90A and 90B.

Carefully inspect any previously installed ductwork to determine suitability.

*Note:* Ductwork should be of a size meeting requirements of the installation. Ductwork should transition gradually from a smaller size blower outlet to required duct run size to avoid excessive loss of air velocity.

### Step 2 - Check duct insulation and vapor proofing

Previously installed heating supply ductwork may already have adequate insulation against excessive heat loss. This insulation may be satisfactory for protection against heat gain from summer cooling. Depending upon application, it may be required to add more insulation.

Externally insulated ductwork must have adequate vapor seal for summer operation, particularly where duct is exposed to high humidity conditions such as in attic, vented crawl space, unconditioned basement or utility room.

### Step 3 - Ductwork.

1. When return air duct connection is smaller than coil inlet opening, construct the transition piece so that vertical and horizontal dimensions of transition do not increase more than one inch for every 7 inches of length.
2. Allow a minimum of 3 feet of straight ductwork preceding equipment inlet.
3. Install unit with  $\frac{1}{8}$  inch pitch toward condensate drain opening.

### Step 4 - Sound Attenuation

Flexible duct connections should be used between the unit and both the supply and return ducts. Unit vibration isolation will be required for both suspended and base mounted units.

### Step 5 - Installation of Condensate Drain

Condensate drain must consist of a minimum of  $\frac{3}{4}$  in. copper tubing or  $\frac{3}{4}$  in. galvanized iron pipe or PVC-type plastic pipe. (Fig. 1.) The condensate drain trap must be properly designed to ensure the removal of condensate (Incorrect trapping can hold water in pan causing overflow.) Be sure drain pitches downward at a slope of one inch every 10 feet.

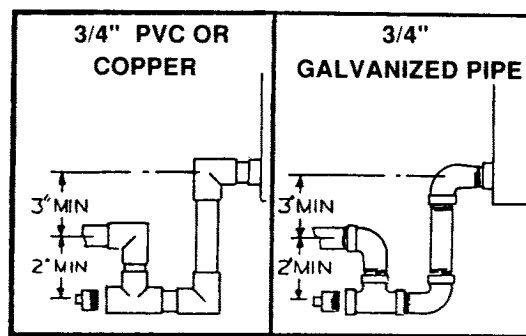

Fig. 1

*Note:* Consult local codes for additional precautions before installing condensate drain.

### Step 6 - Direct expansion refrigerant piping

Always use the condensing unit manufacturer's recommended line sizes. The suction line must be insulated for satisfactory operation. Observe all condensing unit manufacturer's recommendation or requirements. Use refrigerant grade copper only. If unit is to be used when installed as the indoor coil of a heatpump, a by-pass check valve must be used.

*Note:* It is recommended that a freeze-stat (by other) be installed when a hot water coil is used and is mounted in the reheat position.

(Fig. 2) below shows the basic installation of a TXV and the location of the sensing bulb.

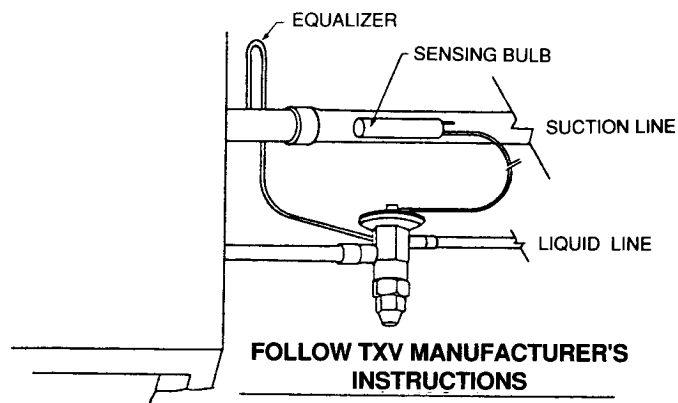
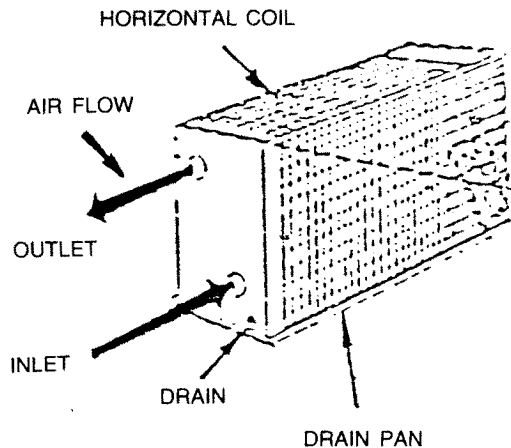

Fig. 2

### Step 7 - Water Piping

All piping must be supported independent of coils. Swing joints or flexible fittings must be provided to absorb expansion and contraction strains. Rigid piping reduces the effectiveness of vibration isolators. The water supply should always be connected so that the entering water is on the leaving air side of the coil (Fig. 3.) Coils must be adequately vented in order to prevent air binding. Freeze-ups due to low air temps. are not covered under the USA Coil Warranty.



COIL CONNECTIONS  
(STANDARD RIGHT HAND UNIT)

Fig. 3

### Step 8 - Motors and drives

Units will normally be shipped with motor and drive installed. However, when mounting a motor on the adjustable base in the field, extreme care should be taken to ensure proper alignment and belt tension.

### Step 9 - Electrical connections

A control box is mounted on each unit and the motor is to be wired to this box.

*Note:* Unit must be permanently grounded in accordance with NEC and local codes and ordinances. See typical wiring diagram. ( Fig. 4.)

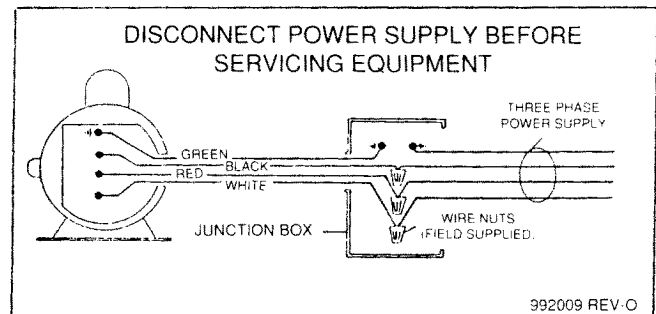
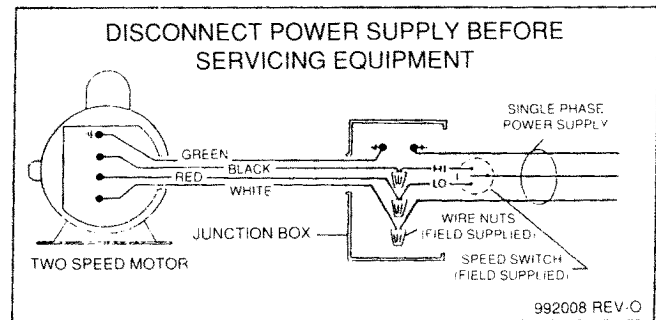
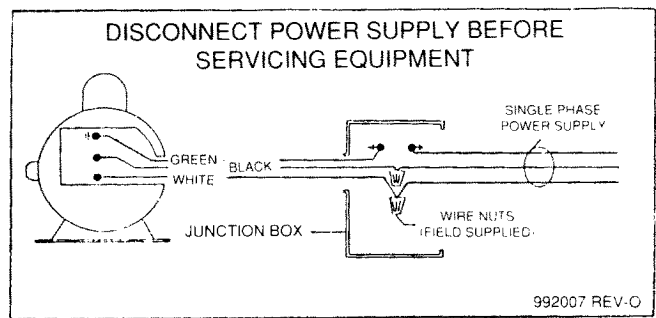

Fig. 4

## MIXING BOX INSTALLATION

(Fig. 5)

### Before Installation

*Note:* See dimensions **Table 1** and **Fig. 5**. Inspect desired installation location. Determine if space provides sufficient work and safety clearances. If determined that ample space is available in work area, make all sheet metal connections and attachments prior to moving completed assembly to duct connection site.

1. One side of mixing box has 2 plastic plugs. These may be removed and moved to opposite end to plug unused  $\frac{7}{8}$  in. holes in end of cabinet where  $\frac{5}{16}$  in. rods do not extend out of cabinet.
2. Choose side of cabinet most accessible for servicing to mount damper motor. Remove bolt for each damper shaft on that end and extend shaft until second bolt hole in shaft lines up with hole in damper blade. Replace bolt. Connect 2 shafts with the 2 crankarms, and the  $\frac{5}{16}$  in. linkage rod furnished with mixing box.

3. Mount damper motor on the selected side of mixing box cabinet by drilling necessary holes and securing with either screws or bolts and nuts.

### Installation

1. Attach mixing box to unit return-air duct flange. Vertical duct flange connections at rear of unit are prepunched to match prepunched holes in mixing boxes. Mixing boxes may be mounted for top-rear or bottom-rear connections.
2. After vertical flange has been bolted, drill holes in horizontal duct flanges. Secure with screws or bolts and nuts.
3. Use field-supplied hardware to connect motor shaft to one of the damper shafts.
4. Connect duct to the 1" duct flange provided on mixing box for return and fresh air makeups as needed.

*Note:* Steps 1, 2, 3 above may follow steps 1, 2 under Before Installation if preferred.

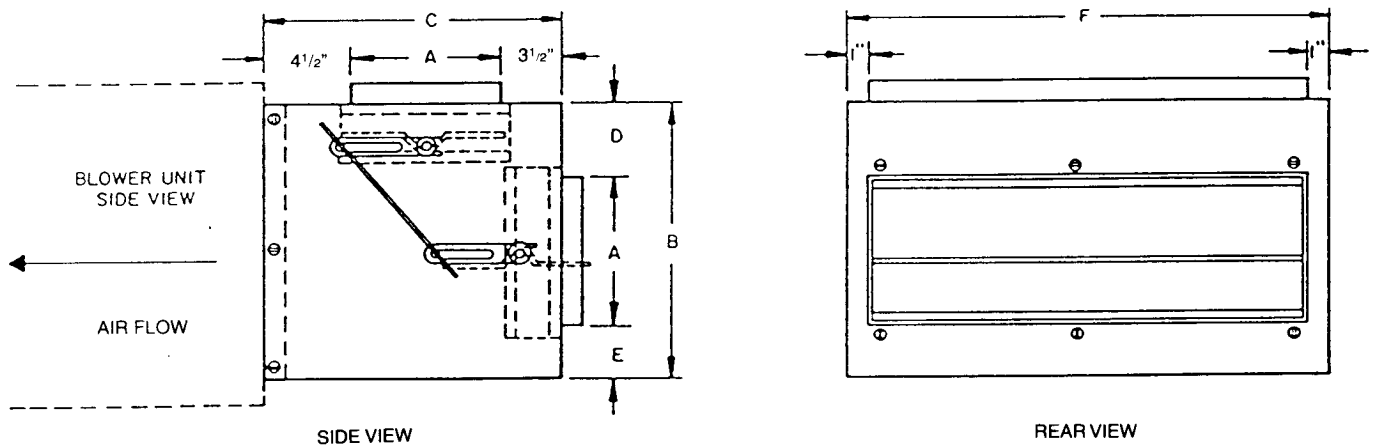
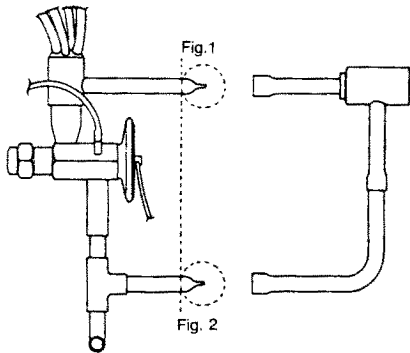

Fig. 5 - Mixing Box Dimensions

**DIMENSIONS TABLE 1**

MODEL	A	B	C	D	E	F	DAMPER	SHIPPING WT.	CFM.	S.P.
48-60-MB	8	20	16	8	4	36	2- 34 X 8	63	2000	.07"
90-120-MB	12	32	20	10	10	48	2- 46 X 12	120	4000	.03"
180-240-MB	14	45	22	15	16	66	2- 56 X 14	205	8000	.04"

## OPTIONAL HEAT PUMP BYPASS ASSEMBLY FOR LXVB SERIES



Expansion Valve  
Distributor Assembly  
as it appears on  
the BMX Units

Check Valve Bypass  
Assembly

### INSTALLATION PROCEDURE

1. Cut off the ends of the stub-out tubes near the location of the dotted line. (See Figure 1 & 2)
2. Slip the swaged ends of the bypass kit over the open tube ends where the ends were cut off.
3. Make sure the bypass assembly is in the same position as shown above.
4. Braze the two joints and then check to be sure there are no leaks in the welded joints.

### START-UP

Ensure all shipping bolts / screws are removed and all other bolts and screws are tight. Never assume the voltage and phase on the unit name plate is the same as the motor is wired. Check the sheaves to see if they are in alignment and ensure the set screws are tight. Check for proper rotation of the blower pulley. Three phase motor rotation can be reversed by exchanging two of the three leads at the unit j box. Not all installations will be on starter. The rotation of single phase motors can be reversed by exchanging leads inside the motor junction box. Refer to motor nameplate. Ensure all filters are installed. Do this with all doors, panels, etc. in place. Check the amperage draw of the motor. This should not exceed the nameplate amps shown on the motor serial plate.

### OPERATION AND MAINTENANCE

#### WARNING

Disconnect electrical power to all circuits before servicing unit. Failure to do so may result in personal injury from electrical shock or moving parts.

**RETURN AIR FILTERS** - Filter access is from either side of unit. Inspect on a regular basis (at least monthly) and clean or replace.

#### CAUTION

Never operate unit without a filter or with filter access door removed. Damage to blower motor may result.

#### - Water Piping - All Drain

Coil is easily cleaned when dry. To check or clean, remove unit access panel, filter access door and filters. Use accepted industry methods for cleaning. Remove all foreign matter from pan and condensate drain line. Check for rust and holes.

**BELT AND PULLEY** - Proper pulley alignment and belt tension must be maintained at all times. Speed is reduced by adjusting pulley faces so they are further apart; speed is increased with faces closer together. Check pulley setscrews and bolts.

**MOTOR** - Use electric motor oil or SAE20 nondetergent oil. Tighten motor mount bracket and base bolts as required. **DO NOT OVER-OIL!!**

**BLOWER** - Check bearing for wear. Replace as required. Check wheel for accumulation of dirt and clean as required.

REPRESENTED BY

OTHER PRODUCTS

STOCK HEATING COILS

33 Sizes each in 1 Row & 2 Row styles for hot water and low pressure steam applications. Coils are flanged for mounting to plenums and ductwork.

STOCK COOLING COILS

Horizontal and Vertical configurations available for DX, capillary or chilled water applications. Coils only or coils with insulated cabinets can be provided.

STANDARD COILS

Complete line of Steam, Hot Water, Booster, DX, Chilled Water and Condenser Coils available.

REPLACEMENT COILS

Customized Coils of almost any style and type available with expedited shipment available at 5 and 10 working days.

INDUSTRIAL COILS

Special Materials include Brass, Cupro-Nickel, Aluminum, Carbon or Stainless Steel. Heavy Duty Preheat and Heat Recovery designs for process are our specialty.

SHELL & TUBE & BUNDLES

Replacement or Customized Chillers - Evaporators, Water Cooled Condensers and Special Tube Bundles for cooling or heating applications.

**U.S.A. COIL & AIR, INC.**  
**1-800-USA-COIL**